

Martin-Till

MartinTill Weight Transfer System (WTS)

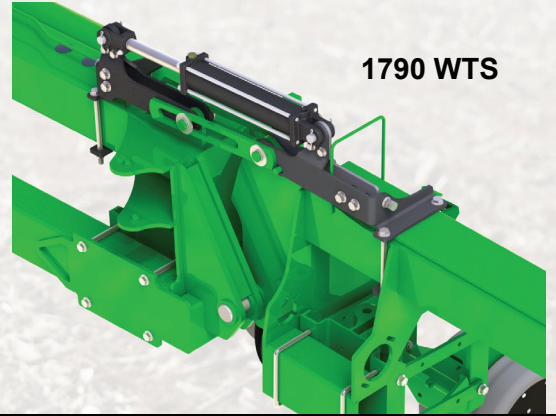
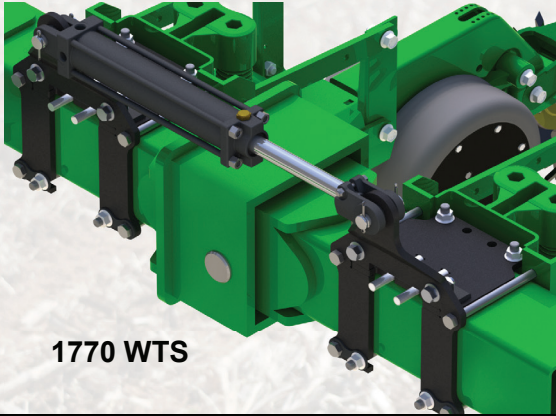

The Martin weight transfer system consists of bolt on brackets, a pressure relieving control valve, an in cab control box and the associated cabling. Transfer of the weight from the center of the planter to the wings reduces compaction and ground pressure, more evenly distributing the weight to where it is needed most to ensure uniform pressures and planting depths from the row units. The valve and control system respond to changes in pressure very quickly, so the system is well capable of maintaining the pressures over rapidly changing field conditions without a problem.

WTS™

Weight Transfer System

- In-Cab Control Box with harness (Electronic PWM version)
- Bolt on brackets. No welding required.
- Grade 8 mounting hardware
- Industry standard durable hydraulic valve
- NOTE: Kit does not include custom hydraulic hoses or fittings
- Kits available for:

JD 1770/1775 12 & 16 Row

JD 1790/1795 12 & 16 Row

JD 1770 24 Row

JD DB60

